

Instructions for BA3200 series plug-in CPU modules

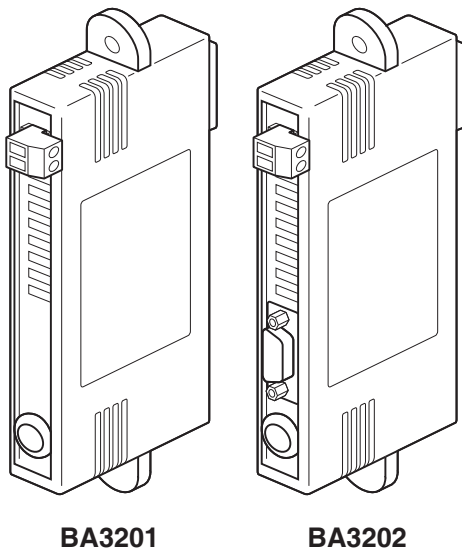

BA3201

BA3202

Issue 4
5th September 2023

BEKA associates Ltd. Old Charlton Rd, Hitchin, Hertfordshire, SG5 2DA, UK
Tel: +44(0)1462 438301 e-mail: sales@beka.co.uk
web: www.beka.co.uk

1. INTRODUCTION

The BA3200 series plug-in CPU (Central Processing Unit) modules are part of the BEKA Pageant Display System. The following models are available, one with external communication:

- BA3201 CPU module without communication
- BA3202 CPU module with RS485-IS communication

All models have IECEx, ATEX and UKEX intrinsic safety apparatus certification.

Fig 1 shows a BA3200 CPU plug-in module with its features identified. It contains a central processor and a removable micro SD card on which is stored the Linux operating system, CODESYS™ runtime programme and the PLC application programme. The CPU module plugs into the 'C' socket at the rear of the BA3101 Pageant Operator Display.

Power for the BA3101 Operator Display and up to seven plug-in input and output modules is distributed via the CPU module from a BEKA Power Isolator in the safe area or Zone 2.

The BA3200 series CPU modules and all of the plug-in input and output modules have individual intrinsic safety apparatus certificates. Compatible input and output safety parameters allow any certified BEKA Pageant CPU module to be fitted in the Pageant Operator Panel 'C' socket without any additional certification.

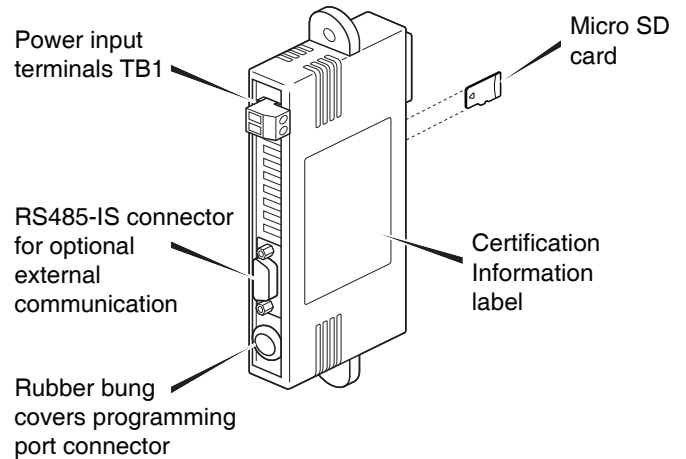

Fig 1 BA3200 series plug-in CPU module

2. INTRINSIC SAFETY CERTIFICATION

Notified Body CML B.V. and UK Approved Body Eurofins CML have issued the BA3200 series plug-in CPU modules with the following apparatus certificates:

IECEX	IECEX CML 20.0152X
ATEX	CML 20ATEX2254X
UKEX	CML 21UKEX2005X

The ATEX certificate has been used to confirm compliance with the European ATEX Directive for Group II, Category 1GD equipment, similarly the UKEX certificate has been used to confirm compliance with UK statutory requirements. All BA3200 series CPU modules carry both the CE and UKCA marks, subject to local codes of practice, they may be installed in any of the European Economic Area (EEA) member countries and in the UK. ATEX certificates are also acceptable for installations in some non EU countries.

These instructions describe IECEx, ATEX and UKEX installations which conform with IEC / EN 60079-14 *Electrical installations design, selection and erection*. When designing systems the local code of practice should be consulted.

Plug-in BA3200 series Pageant CPU Modules are CE marked to show compliance with the European Explosive Atmospheres Directive 2014/34/EU and the European EMC Directive 2014/30/EU.

The modules are also UKCA marked to show compliance with UK statutory requirements Equipment and Protective Systems Intended for Use in Potentially Explosive Atmospheres Regulations UKSI 2016:1107 (as amended) and with the Electromagnetic Compatibility Regulations UKSI 2016:1091.

2.1 Zones, gas groups and T rating

All of the BA3200 series CPU certificates specify the same code:

Ex ia IIC T4 Ga
 Ex ia IIIC T120°C Da*
 $-40^{\circ}\text{C} \leq \text{Ta} \leq 65^{\circ}\text{C}$

* Dust certification requires the Pageant Operator Display and the BA3200 series CPU module to have IP54 rear protection.

Intrinsic safety parameters for power input terminals TB1:

U_i = 12.4V
 I_i = 2680mA
 P_i = 5.44W
 C_i = 0
 L_i = 0

2.2 Powering a BA3200 series CPU module

The BA3101 Pageant Operator Display and all of the plug-in modules are powered via the BA3200 series CPU modules TB1 terminals. The intrinsic safety input parameters of these terminals match the output parameters of a BEKA BA212 Power Isolator. This allowing direct connection between the two for applications in gas groups IIA and IIB and in dust hazardous atmospheres.

For most applications in a IIC gas hazardous atmosphere a BEKA BA243 Power Isolator should be used. This has four galvanically isolated intrinsically safe outputs which are remotely combined by a certified BA3901 4 way Power Combiner allowing longer field cables to be used. The intrinsic safety parameters of the four BEKA BA212 outputs match the input parameters of the CPU module and power combiner allowing a direct connection between the two.

For further information about maximum permitted cable lengths please see the Pageant System Operator Panel Instructions and the BEKA Application Guide AG210.

2.3 Special conditions for safe use

All three CPU apparatus certificate numbers have an 'X' suffix indicating that the following special conditions apply, please see certificates for full details:

- i. Under certain extreme circumstances, the non-metallic parts incorporated in the enclosure of this equipment may generate an ignition-capable level of electrostatic charge. Therefore, the equipment shall not be installed in a location where the external conditions are conducive to the build-up of electrostatic charge on such surfaces. In addition, the equipment shall only be cleaned with a damp cloth.
- ii. In installations requiring EPL Da, Db, or Dc, the equipment shall be mounted to an enclosure which provides a minimum degree of protection of IP5X and which meets the requirements of EN60079-0 Clause 8.4 (material composition requirements for metallic enclosures for GroupIII) and/or EN60079-0 Clause 7.4.3 (Avoidance of a build up of electrostatic charge for Group III) as appropriate.

All cable entries into the equipment shall be made via cable glands which provided a minimum degree of protection of IP5X.

- iii. The equipment shall only be connected to programming equipment via SK2 when in the safe area and shall only be connected via the galvanically isolating interface unit provided by the manufacturer. (BA3902 Programming Cable)

2.4 RS485-IS communications

The BA3202 plug-in CPU module include an RS485-IS communications port. This is a galvanically isolated intrinsically safe port complying with the physical layer requirements specified by the Profibus RS 485-IS User and Installation Guideline, version 1.1.

The port has the following safety parameters:

U_i = 4.2V
 U_o = 3.8V
 I_o = 132mA
 P_o = 126mW
 C_i = 0
 L_i = 0

Pin no.	Signal	Meaning
1	Shield	Cable screen
2	NC	
3	RxD/TxD-P	Received / transmitted data P; wire B
4	NC	
5	ISGND	Bus termination ground
6	ISP	Bus termination plus
7	NC	
8	RxD/TxD-N	Received / transmitted data N; wire A
9	NC	

Pin numbers for female 9-pole D-sub RS485-IS connector on BA3402

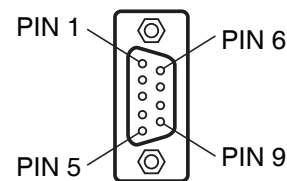

CAUTION

When the port is fitted with a sub D9 male or BA3903 connector, the bus cable must be supported to prevent vibration damage to the connectors.

2.5 Certification label information

The certification information label is fitted to the side of the BA3200 series plug-in CPU module. It shows the model number, certification information, BEKA associates address and year of manufacture together with the serial number.



BA3201 certification information label0

3. I NSTALLATION

The BA3200 series plug-in CPU module should be fitted into the 'C' socket of a BA3101 Pageant Operator Display as shown in Fig 2.

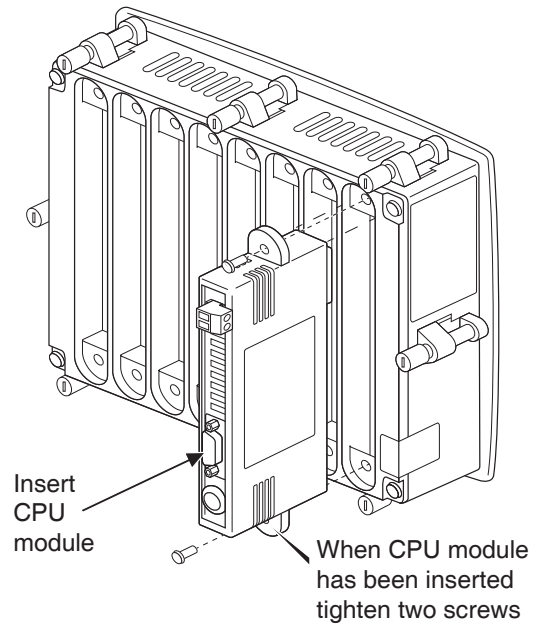

Fig 2 Inserting BA3200 series module into the 'C' socket

For a hazardous area installation the plug-in CPU module must be manufactured by BEKA and have certification that specifies that it should be used with a BEKA Pageant system

3.1 BA3200 series plug-in CPU Installation

1. The BA3200 series CPU module may be fitted before or after the Operator Display is installed, but the CPU module should not be powered while being added or removed.
2. Carefully insert the CPU module into the 'C' socket at the rear of the Pageant BA3200 series Operator Display as shown in Fig 2. When correctly positioned secure the assembly by tightening the two module fixing screws.
3. For applications in a IIA or IIB flammable gas atmosphere or in a combustible dust atmosphere, connect a twisted pair instrument cable between terminals TB1 on the CPU module to a BA212 Power Isolator located in a safe area or Zone 2. *

For most applications in a IIC gas atmosphere mount a BA3901 4 way Power Combiner on the rear of the CPU module and connect its terminals to a BA243 Power Isolator located in a safe area or Zone 2 with four twisted pair instrument cables. *

* For detailed information about types of cables and maximum permitted lengths see Pageant Operator Panel System instructions and BEKA Application Guide AG210.

4. MAINTENANCE

The BA3200 series CPU module should be regularly inspected to ensure that it has not been damaged. The frequency of inspection depends upon environmental conditions.

No attempt should be made to repair a faulty BA3200 series plug-in CPU module. Suspect modules should be returned to BEKA associates or your local BEKA agent.

5 Transferring a PLC application file to Pageant

After a new or modified PLC application file has been developed within a CODESYS Integrated Development Environment (IDE) it can be transferred to the Pageant Operator Panel in a number of ways.

- a. The easiest and fastest technique is to unplug the CPU module from the Hazardous area Pageant Operator Panel and remove the micro SD card as shown in Fig 3.

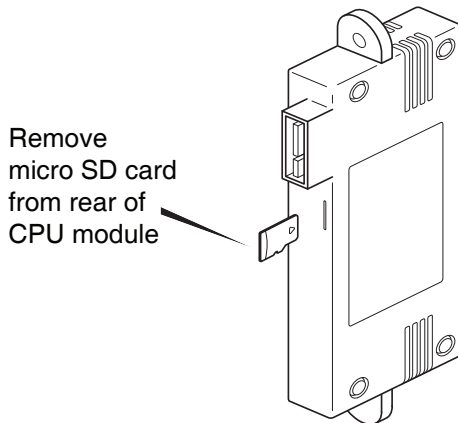

Fig 3 Removing micro SD card from plug-in CPU module

Using an SD card writer the revised compiled PLC application code can be copied to the micro SD card in a safe area. A Windows based system will show 4 removable drives on the SD card:

- Kernel
- Unknown Format
- Unknown Format
- BEKA
 - |----Logs
 - |----Runtime Update
 - |----User Data
 - |----User Program Update

The compiled PLC application file should be copied to the User Program Update area. Additional information about transferring compiled PLC application files is contained in the Pageant Operator Panel System instructions.

After the revised compiled PLC application file has been copied to the SD card, the card should be replaced in the CPU module and the module reinstalled in the Pageant Operator Panel.

- b. Alternatively, if a duplicate Pageant Operator Panel is available in a safe area, the hazardous area Operator Panel CPU module should be transferred to the safe area Pageant Operator Panel. Using a BA3902 Programming Cable to connect a USB port on the PC hosting the CODESYS IDE to the programming port on the CPU module, the compiled updated PLC application file can be copied to the CPU module. Finally, the CPU module should be transferred back in the hazardous area Pageant Operator Panel.

The BA3902 Programming Cable shown in Fig 4 ensures that the intrinsic safety components within the CPU module are not damaged if a fault develops in the PC.

When installing or removing a plug-in CPU module in a Pageant Operator Display, the CPU module should not be powered.

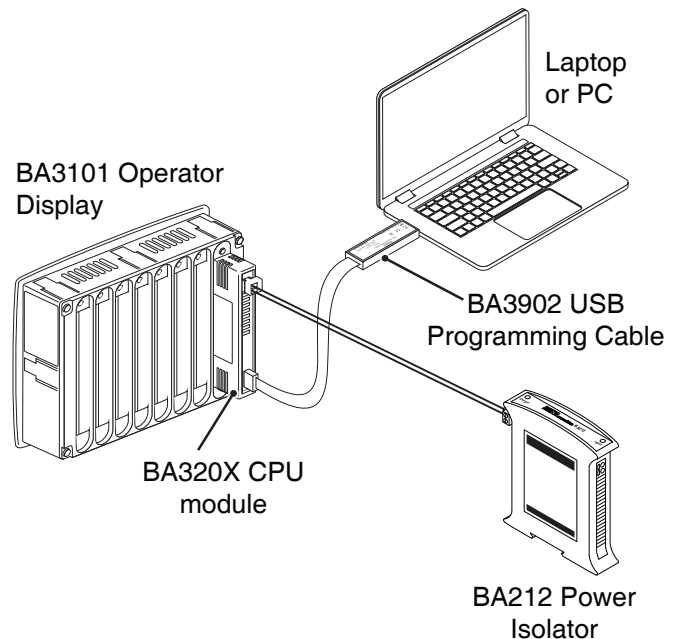

Fig 4 Transferring PLC application file to Pageant in a safe area

- c. If a gas clearance certificate is available for the hazardous area in which the Pageant Operator Panel is installed, method b can be used to transfer the compiled PLC application file directly to the CPU module in hazardous area Pageant Operator Panel.

CAUTIONS

Unless a gas clearance certificate is available, BA3200 series CPU modules should only be reprogrammed in a safe area.

A BEKA BA3902 CPU Module Programming Lead should be used to connect the programming port to the programming computer.

6. GUARANTEE

BA3200 series CPU modules which fail within the guarantee period should be returned to BEKA associates or your local BEKA agent. It is helpful if a brief description of the fault symptoms is provided.

7. CUSTOMER COMMENTS

BEKA associates are always pleased to receive comments from customers about our products and services. All communications are acknowledged and whenever possible, suggestions are implemented.



All associated manuals, certificates, and
datasheets can be downloaded from
<https://www.beka.co.uk/qr-ba3100>

BEKA *associates*

Old Charlton Rd, Hitchin, Hertfordshire, SG5 2DA, UK
Tel: +44(0)1462 438301 e-mail: sales@beka.co.uk
web: www.beka.co.uk